



8 Winter Street Newington VIC

3 1 1

Nestled in one of Newington's most tightly held pockets, 8 Winter Street offers timeless charm, exceptional liveability and an enviable lifestyle on the fringe of Ballarat's premier attractions. Set on a generous 668m² (approx.) allotment, this beautifully maintained three-bedroom home combines classic character with everyday convenience, making it an ideal choice for families, couples and investors alike. Light-filled and inviting, the home features a well-proportioned living area, light filled kitchen, and a functional central bathroom, while the expansive backyard provides endless potential for gardening, entertaining or future extension (STCA). With ample off-street parking and excellent shedding, the property caters perfectly to tradies or those seeking extra storage. Positioned within walking distance to prestigious schools, Victoria Park, Lake Wendou ...

Price : \$ 530,000

Land Size : 669 sqm

View : <https://www.ballaratrealestate.com.au/sale/vic/ballarat-western-district/newington/residential/house/8556048>



Damian Larkin
03 53312233
0417 088 755

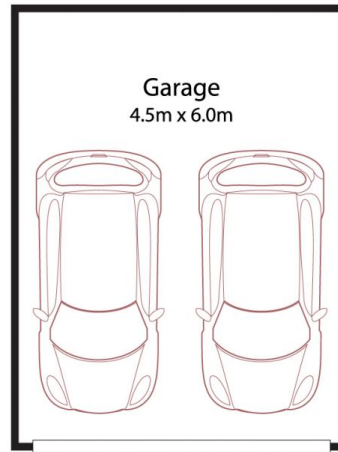

Not In Position

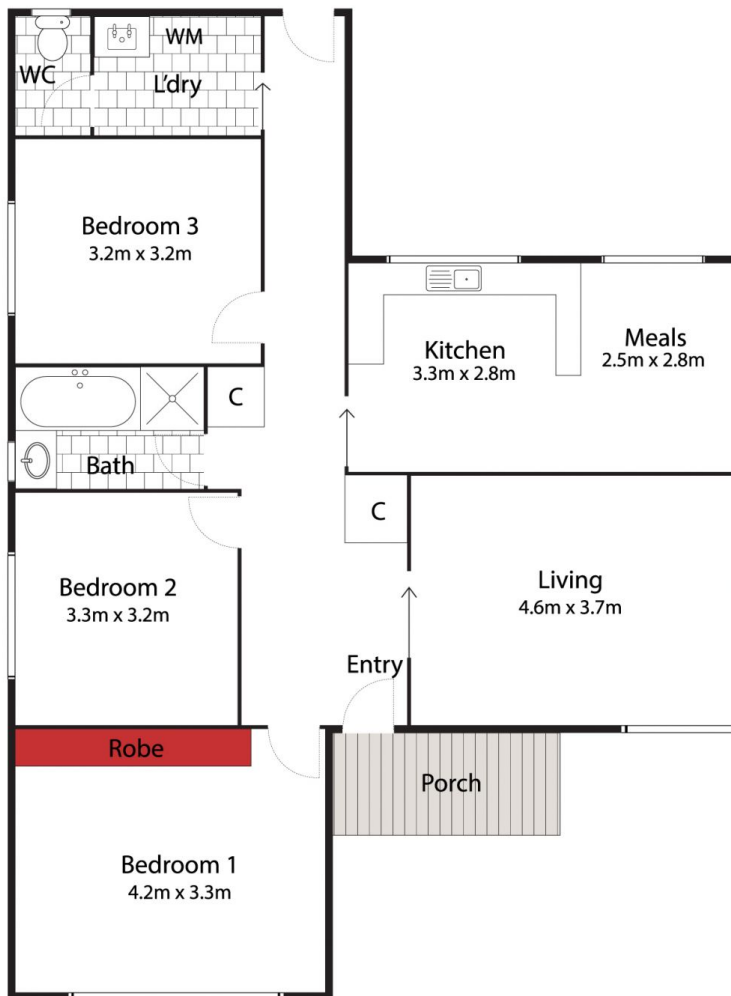

3 1 2

Whilst klapper films has made every attempt to ensure the accuracy of the floor plan contained here, measurements are approximate and no responsibility is taken for any error, omission, or mis-statement. This plan is for illustrative purposes only.

8 Winter Street, Newington

Ballarat
Real Estate

